

Innovative Compressed Air Filter GD Series

The new Gardner Denver filters were developed on the basis of world-wide experiences and innovative designs for highly efficient and economic filtration technology.

The intelligent overall concept of the filter unites the following characteristics:

- High performance
- Efficiency
- Compactness
- Easy of use
- Flexibility
- Safety

Hence, the following aspects have to be considered in high quality compressed air purification.

- Economic filtration
- Validated performance data according to ISO 12500-1
- Reliable achievement of compressed air quality suitable to the application according to ISO 8573-1

The new GD filters are unrivalled in its ease of use. This is evident both during installation and when filter element is replaced.

All filters can be either used as coalescence filters (flow through element form the inside to the outside) or as particulate filters (outside to inside).



The combination of filter grades installed in series is provided through connection adapters. Simply to mount and space-saving to even fit into smallest spaces.



Optional Economizer

Besides energy cost savings by the filter design, the use of the Economizer offers further saving achievements through timely replacement of the used filter elements. The most cost-effective replacement time for the filter element is calculated and LEDs then signal that the "filter exchange" is necessary.

Standard

Type with float condensate drain and Econometer

Optional

Economizer

BEKOMAT Condensate Drains

A selection of appropriate filter grades by filter element types ensure that the right product for the filtration task is always available to the user. The filter housing design allows an easy replacement of the filter element. The filter bowl is rotated slightly via a bayonet lock and can be removed together with the filter element. For this a installation height of only a few centimetres of ground clearance is necessary.

Technical Data

Features:	Benefits:
Validated performance data acc. to ISO 12500-1	Reliable achievement of compressed air quality acc. to ISO 8573-1
Intelligent overall concept	Flow range, filtration grades, efficiencies and available options perfectly meet requirements of industrial air purification
Flow-optimised filter housing and filter element design	Low pressure losses, thereby saving of energy costs
Bayonet fixing between filter head and filter bowl; element can be removed together with filter bowl; filter head with integrated differential pressure indicator can be rotated	Easy to use construction - simplified filter replacement; simple installation and assembly
Little installation height for the filter element exchange, differential pressure indicator integrated in filter head	Compact, space-saving construction - installation within smallest space possible
Changing the coding clip inside the filter cover allows the filter element to be rotated and thus change the flow direction	High flexibility - filters can be either used as coalescence filters or particulate filters
Filter cannot be opened under pressure due to bayonet lock	High safety during operation
Filter housings immersion-laquererd on the inside and outside surface	Ensures long-term corrosion protection, in particular against aggressive condensates
Options:	
Economizer 	Differential pressure indicator for the determination of the most economical time for replacement of the filter element; Possibility of remote data transmission
BEKOMAT	Electronic Condensate Drains
Wall bracket	Distance to the wall gradelessly adjustable (except QA-0045)
Connection adapter	Intelligent adapter solution for filter combination
Filter elements	V / M / S (coalescence filter)
	P (pre filter)
	A (activated carbon filter)

Filter Elements:

Particle filter	Initial differential pressure : 0,15 bar Efficiency : 100% related to 25 µm
Activated carbon filter	Initial differential pressure : 0,18 bar Residual oil content : 0,003 mg/m ³
Coalescence filter	Initial differential pressure : 0,14 bar Residual oil content: < 0,2 mg/m ³
Coalescence filter	Initial differential pressure : 0,22 bar Residual oil content : < 0,02 mg/m ³
Coalescence filter	Initial differential pressure : 0,24 bar Residual oil content : < 0,01 mg/m ³

1 related to nominal performance at 7 bar, dry condition

2 related to an inlet concentration of 3 mg/m³

3 when upstream connected a M- or S-filter

Filter - Standard Version

Pos.	Pcs.	Description
1	1	Filter head
2	1	Lower housing bowl
3	2	Wall bracket (option)
4	1	Econometer
5 0045 - 0860	1	Internal automatic drain
6 1200	1	External automatic drain

Materials	
Filter housing	Aluminium die cast
Econometer	Polymer
Float drain	Polymer / aluminium mold cast
Sealings	Viton

Max. operating pressure	16 bar
Test pressure	22.9 bar
Perm. operating temperature	+1°C / +65°C

Classification acc. to 97 / 23 / EG for fluids group 2	
0045 - 0350	Art. 3, par. 3
0510 - 1200	Cat. I

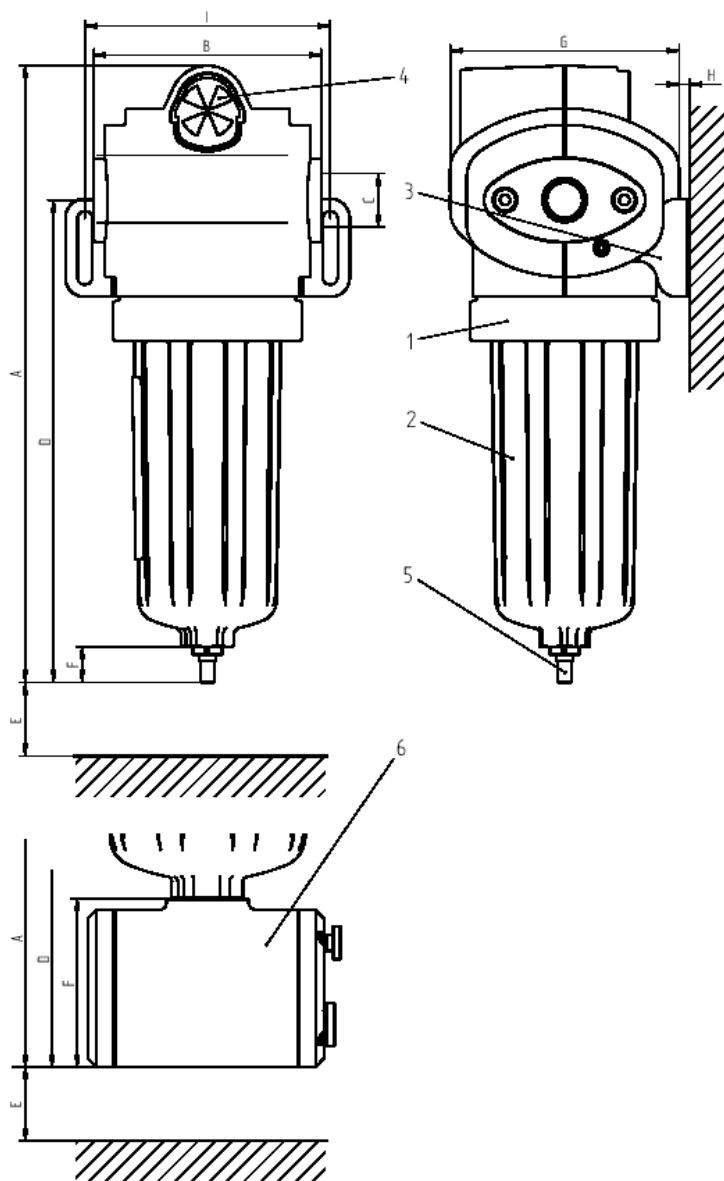

Size housing/ element	Flow rate* m ³ /h	Volume (l)	Weight** (kg)	A mm	B mm	C	D mm	E mm	F mm	G mm	H min./ max. mm	I mm
0045	45	0.20	0.5	254	76	G 3/8	186	100	27	85	5	84
0085	85	0.40	0.9	297	103	G 1/2	222	115	27	107	5 / 34	107
0140	140	0.50	1.0	341	103	G 1/2	266	150	27	107	5 / 34	107
0240	240	1.15	2.0	382	139	G 1	300	180	27	140	5 / 53	150
0350	350	1.50	2.2	442	139	G 1	360	250	27	140	5 / 53	150
0510	510	5	5.2	586	190	G 1 1/2	487	250	27	203	5 / 73	190
0680	680	5	5.2	586	190	G 2	487	250	27	203	5 / 73	190
0860	860	5	5.2	586	190	G 2	487	250	27	203	5 / 73	190
1200	1200	6	7.2	764	190	G 2	665	250	103	203	5 / 73	190

* Nominal flow at 7 bar g, m³/h related to 1 bar abs. and 20°C

** without filter element